



SUMMER– 15 EXAMINATION

Subject Code: **17535**

Model Answer

Important Instructions to examiners:

- 1) The answers should be examined by key words and not as word-to-word as given in the model answer scheme.
- 2) The model answer and the answer written by candidate may vary but the examiner may try to assess the understanding level of the candidate.
- 3) The language errors such as grammatical, spelling errors should not be given more Importance (Not applicable for subject English and Communication Skills).
- 4) While assessing figures, examiner may give credit for principal components indicated in the figure. The figures drawn by candidate and model answer may vary. The examiner may give credit for any equivalent figure drawn.
- 5) Credits may be given step wise for numerical problems. In some cases, the assumed constant values may vary and there may be some difference in the candidate's answers and model answer.
- 6) In case of some questions credit may be given by judgement on part of examiner of relevant answer based on candidate's understanding.
- 7) For programming language papers, credit may be given to any other program based on equivalent concept.



Q.1 a) Attempt any THREE

12 marks

1) Define Sampling theorem and state Nyquist Rate.

Ans: (**Theorem – 2 marks, Nyquist Rate – 2 marks**)

Theorem states that, 'If the sampling rate in any pulse modulation system exceeds twice the maximum signal frequency, the original signal can be reconstructed in the receiver with minimum distortion.'

Mathematically it is expressed as,

$$f_s \geq 2 f_m$$

Where, f_s = sampling frequency

f_m = maximum frequency of continuous original signal.

Nyquist Rate:

The minimum sampling rate of ' $2f_m$ ' samples per second for a signal $x(t)$ having maximum frequency of ' f_m ' Hz is called as Nyquist Rate.

2) List different types of errors and their causes.

Ans: (**Types of errors – 2 marks, any two relevant causes of errors – 2 marks**)

Types of errors (2 Marks)

The errors introduced in the data bits during their transmission can be categorized as,

1. Content errors
2. Flow integrity errors

Depending on the number of bits in the error, the errors can be classified into two types as:

1. Single bit error
2. Burst error

Causes of errors: (any 2 relevant points- 2 Marks)

Due to addition of noise in transmission & reception of data following errors occur.

1. If data block is lost in the network as it has been delivered to wrong destination.
2. If two or more bits from data unit such as a byte change from 1 to 0 or 0 to 1.

3) State need of multiplexing in communication.

Ans: (**Relevant correct answer – 4 marks**)

Need of multiplexing:

- In telephone systems, there are large numbers of users involved.
- It is not possible to connect separate wires from each subscriber to all other subscribers.
- It is very expensive and increases complexity.
- Instead we can use a communication medium such as a coaxial cable or optical fiber cable to carry many telephone signals from different sources together.
- This can be achieved by 'Multiplexing'.

4) List advantages of Spread Spectrum (SS) modulation over other.

Ans: (Any four correct points – 1 mark each)

Advantages of Spread Spectrum Modulation are:

1. Low Power Density
2. Redundancy
3. Anti-jamming (A/J)
4. Anti-interference (A/I)
5. Low Probability of Intercept (LPI)
6. Message Privacy
7. High Resolution Ranging and Timing

Q.1 b) Attempt any ONE

6 marks

1) Draw the block diagram of digital communication system and explain in detail.

Ans: (Diagram – 3 marks, explanation – 3 marks)

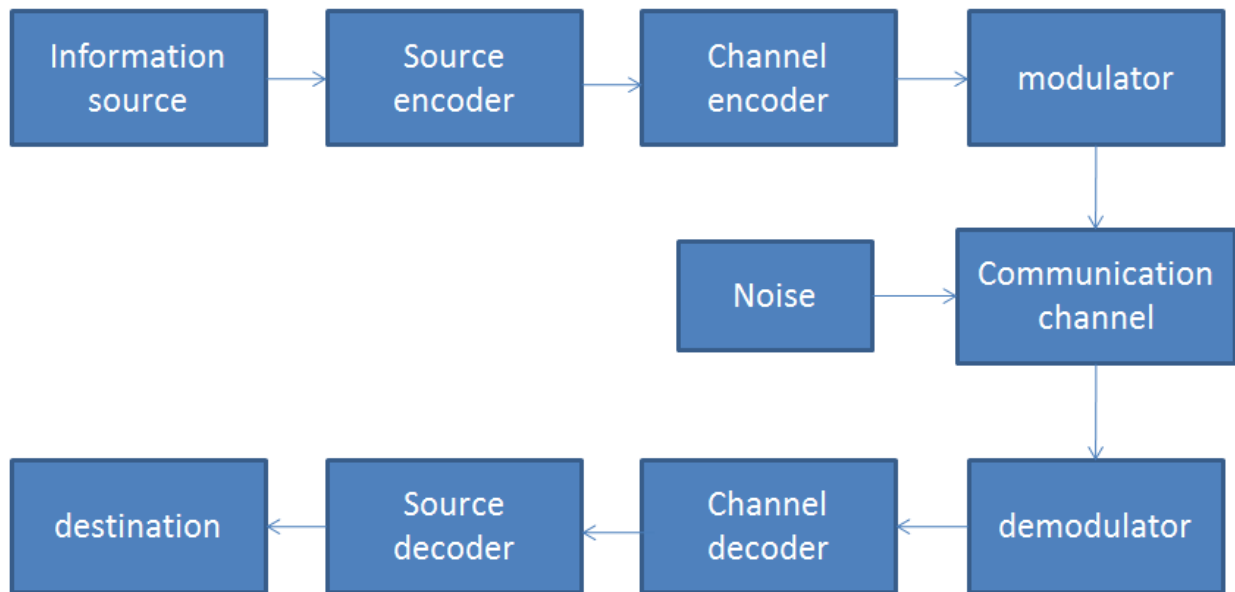

(OR)

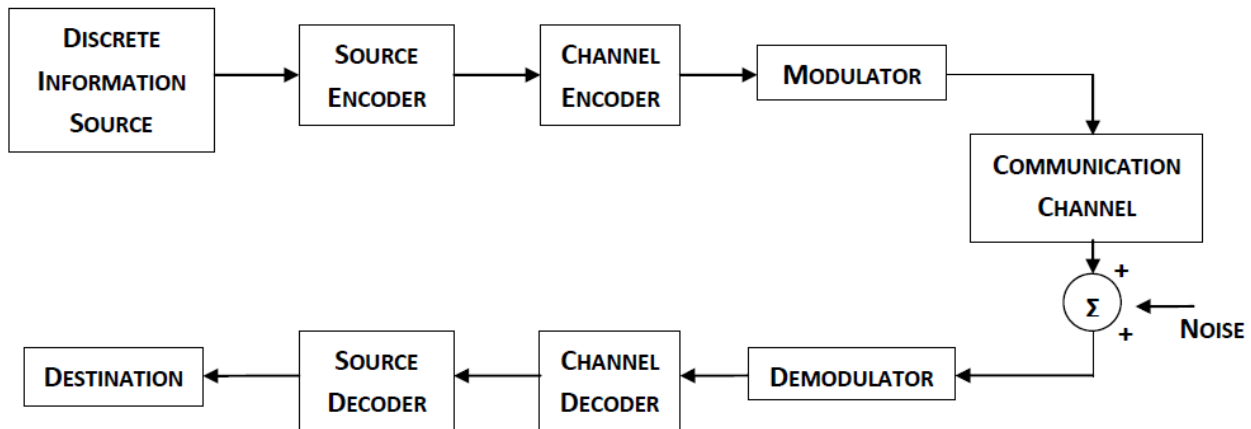



- 1) **Information source-** it may be in analog form. Output of microphone gives analog signal. And if source is computer data then it is a digital form.
- 2) **Source encoder-** the source encoder converts the signal produced by the information source into DataStream. If i/p signal is analog it can be converted in to digital form using A to D converter. If the i/p to the source encoder is a stream of symbols it can be converted into a stream of 1s and 0s using some coding mechanism.
- 3) **Channel Encoder-** if we have to encode the information covertly, even if errors are introduced in the medium. We need to put some additional bits in the source, so that additional information can be used to detect and correct the errors, this process of adding bits is done by channel encoder. In channel encoding redundancy is introduced so that at the receiving end the redundancy is introduced so that at the receiving end redundant bit can be used for error detection and error correction.
- 4) **Modulator-** here the modulation is done for transferring the signal, so that the signal I can be transmitted through the medium easily.
- 5) **Channel-** it is the medium through which the o/p of modulator along with some noise is transmitted and gives to demodulator. This channel is called discrete channel because its input as well as o/p both are in discrete nature.
- 6) **Demodulator-** it performs inverse operation than that of modulator.
- 7) **Channel decoder-** it checks the received bits and also detect and correct the errors, using additional data introduced by channel encoder.
- 8) **Source decoder-** it converts the bit stream in to actual information, here digital to analog conversion is done if the symbols are coded in to 1s and 0s at the source decoder the bits are converted in to symbols.

2) Explain Shannon Hartley's theorem with suitable example.

Ans: (**Theorem statement with expression – 3 marks, example – 3 marks**)

The channel capacity of a white, band limited Gaussian channel is given by,

$$C = B \log_2 \left(1 + \frac{S}{N} \right)$$

Where, B = Channel Bandwidth

S = Signal Power

N = Noise within the channel bandwidth

For example, if the bandwidth of the channel is 10 kHz and the signal to noise ratio is 20 dB then the channel capacity will be calculated as

$$C = B \log_2 \left(1 + \frac{S}{N} \right) \text{ Where } \frac{S}{N} = 20 \text{ dB. Therefore, } \left[\frac{S}{N} \right]_{dB} = 10 \log_{10} \left[\frac{S}{N} \right]$$

$$\text{Therefore, } 20 = 10 \log_{10} \left[\frac{S}{N} \right]. \text{ Hence } \left[\frac{S}{N} \right] = \text{Antilog } 2 = 100$$

$$C = 10 \times 10^3 \log_2 \left(1 + \frac{S}{N} \right)$$

$$C = 10 \times 10^3 \log_2(101) = 66582.1 \text{ bits/sec}$$

Q.2 Attempt any TWO

16 marks

1) Draw and explain PCM Transmitter and state any two advantages and two disadvantages.

Ans: (Transmitter diagram – 2 marks, explanation – 2 marks, any two advantages and disadvantages – 2 mark each)

PCM Transmitter Diagram

(2 Marks)

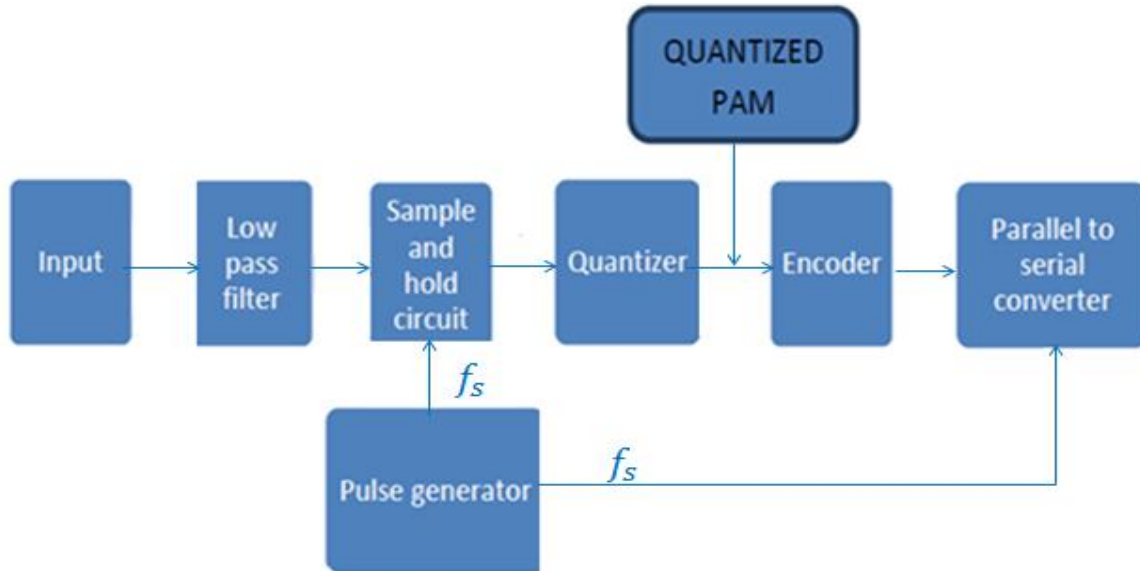

(OR)

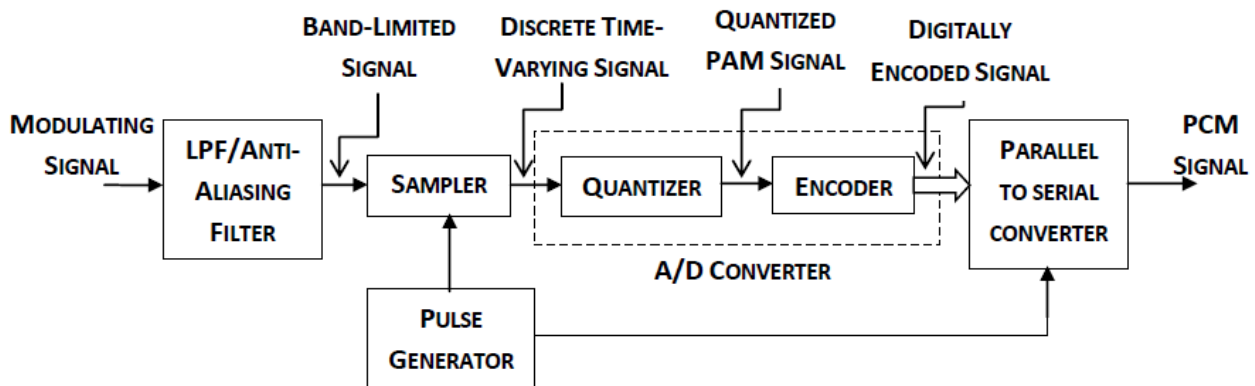

PCM Transmitter Explanation

(2 Marks)

- The analog signal $x(t)$ is passes through band limiting / low pass filter, which has a cut-off frequency $f_c = W$ Hz. This will ensure $x(t)$ will not have any frequency component higher than “W”. In other words, suppresses high frequency components and passes only low frequency signal to avoid ‘aliasing error’.
- The band limited analog signal is then applied to sample and circuit where this circuit acts as modulator and both modulating input signal and sampling signal with adequately high sampling rate are inputs to this circuit. Output sample and hold block is a flat topped PAM signal.



- These samples are subjected to operation “quantization” in the “quantizer”. The quantizer is used to reduce effect of noise. Quantization is a process of approximation of the value of respective sample in to a finite number that will reduce data bits. The combined effect of sample and quantization produces is ‘Quantized PAM’ at the quantizer output.
- The Quantized PAM output is analog in nature. So to transmit it through digital communication system the quantized PAM pulses are applied to an encoder which is basically A to D convertor. Each quantized level is converted into N bit digital word by A to D converter.
- The communication system is normally connected to each other using a single cable i.e. serial communication. But the output of ADC is parallel which cannot be transmitted through serial communicating links. So this block will convert the parallel data into serial stream of data bits.
- A pulse generator produces train of rectangular pulses of duration “t” seconds. This signals acts as sampling signals for the sample and hold block. The same signal acts as “clock” signals for parallel to converter .the frequency “f” is adjusted to satisfy the criteria.

Advantages: (2 Marks)

1. PCM has very high noise immunity.
2. Repeaters can be used between the transmitter and the receiver which can further reduce the effect of noise.
3. It is possible to store the PCM signal due to its digital nature.
4. It is possible to use various coding techniques so that only the desired receiver (user) can decode the message.

Disadvantages: (2 Marks)

1. The encoding decoding & quantizing circuitry of PCM is complex.
2. PCM requires a large BW as compared to other systems.

2) List different digital modulation techniques and explain amplitude shift keying modulation in detail.

Ans: (List of modulation – 3 marks, ASK block diagram – 2 marks, explanation – 2 marks, waveform – 1 mark)

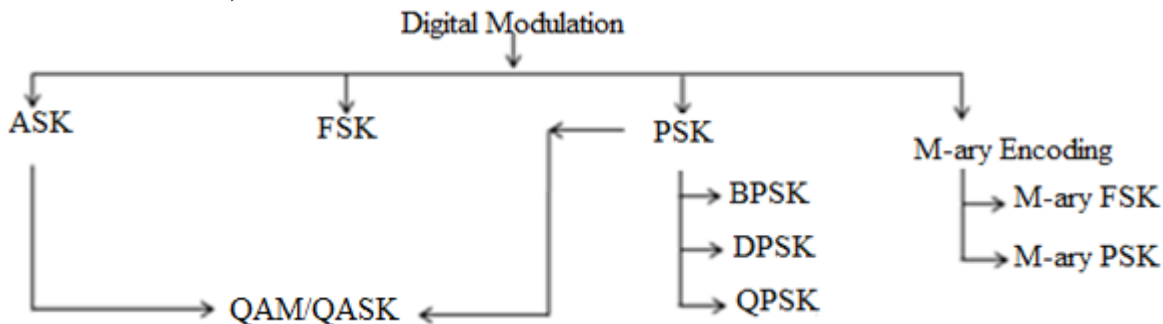

Amplitude Shift Keying (ASK) is the digital modulation technique in which the amplitude of the sinusoidal carrier will take one of the two predetermined values in response to 0 or 1 value of the digital input modulating message signal.

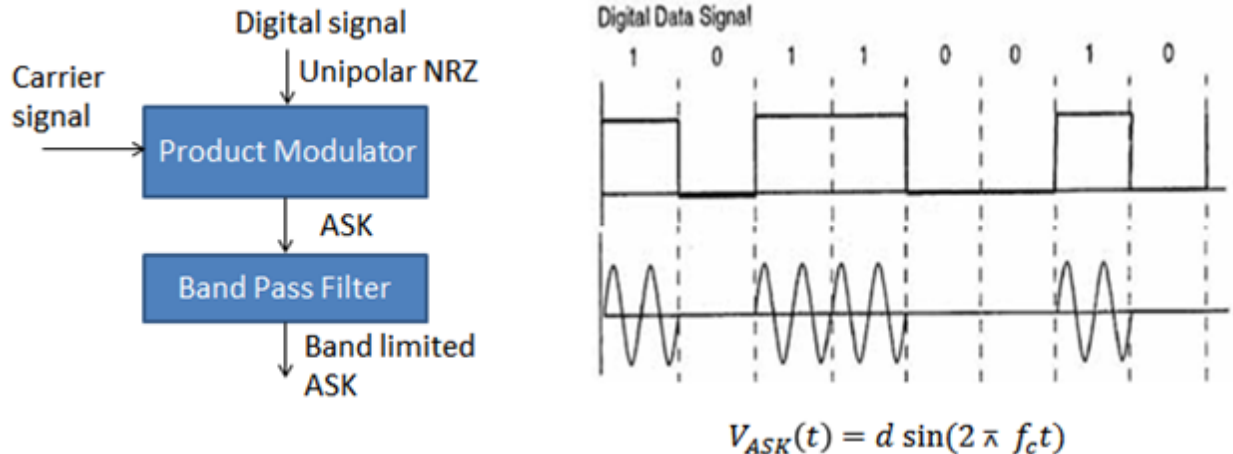

Explanation

- Amplitude shift keying is the simplest form of digital modulation. Here the carrier is a sine wave of frequency (f_c).
- The carrier signal can be mathematically expressed as $e_c = \sin(2\pi f_c t)$
- The digital signal from the information source is a unipolar NRZ signal which acts as the modulating signal. The ASK modulator is nothing but a multiplier followed by a band pass filter as shown in above figure.
- Due to multiplication, the ASK output will be present only when a binary '1' is to be transmitted and when the digital input is '0' then we get zero output as shown in the waveform above.
- From the waveform analysis we can conclude that when a binary '1' is to be sent the carrier is transmitted and when binary '0' is to be sent then the carrier is not transmitted.
- Mathematically ASK signal can be expressed as;

$$V_{ASK}(t) = d \sin(2\pi f_c t)$$

Where d = data bit which can take values 1 or 0

Therefore, $V_{ASK}(t) = \sin(2\pi f_c t)$ When $d = 1$

$V_{ASK}(t) = 0$ When $d = 0$

3) Draw and explain block diagram of Time Division Multiplexing (TDM) and state its advantages (min. 4).

Ans: (TDM block diagram – 3 marks, explanation – 3 marks, any four advantages – 2 marks)

Diagram: TDM Block diagram

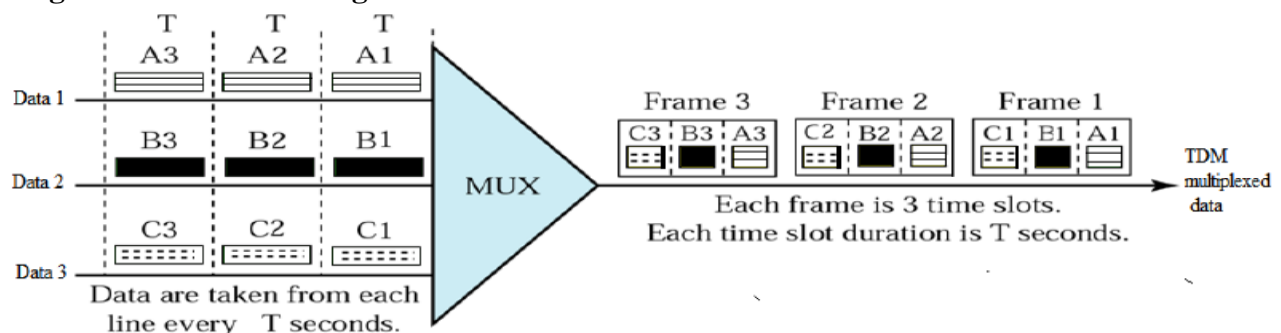

(OR)

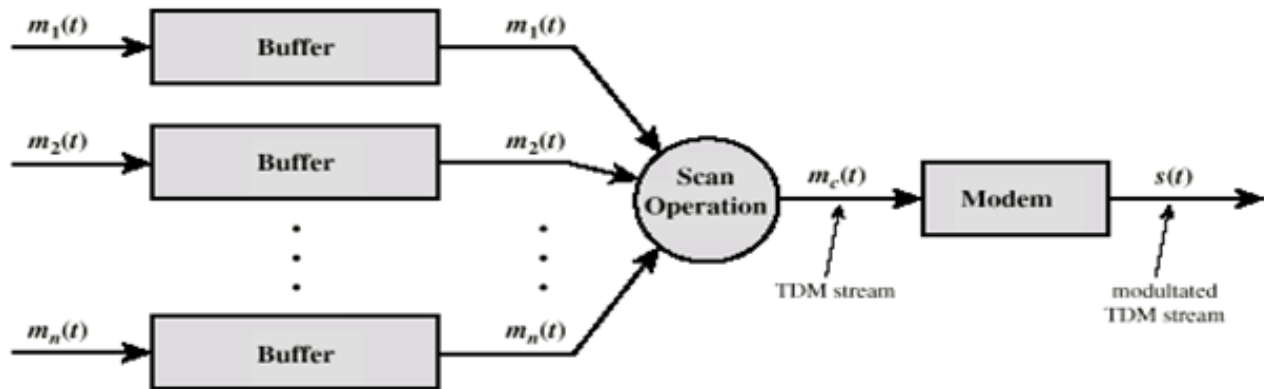

Fig: TDM Transmitter

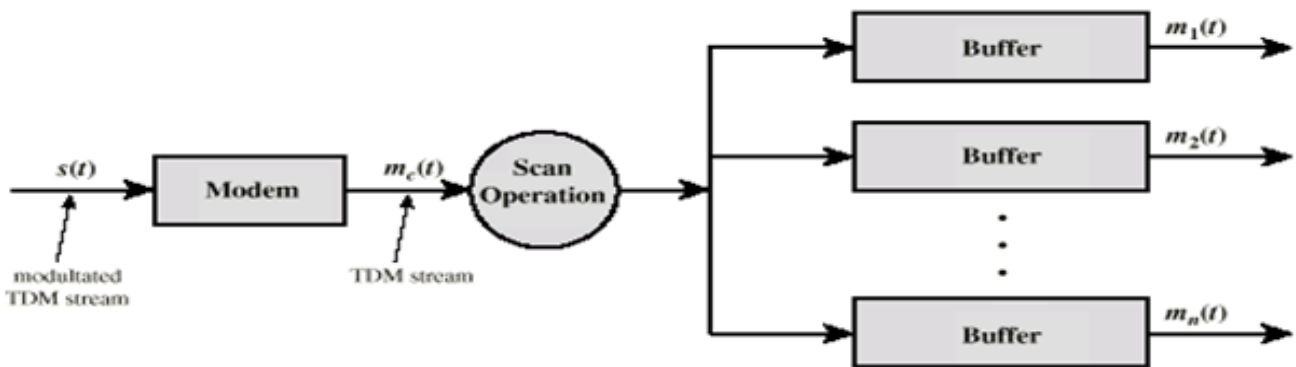

Fig: TDM Receiver

Note: TDM Transmitter or Receiver with explanation should be considered and given marks. Any relevant diagram should be considered

Explanation

- Process of combining digital signals from several sources whereby each connection occupies a portion of time in the link is called Time Division Multiplexing (TDM).
- Links are sectioned by time rather than frequency.
- Data flow of each connection is divided into units.
- In TDM data units from each input connection is collected in to a frame i.e link combines one unit of each connection to make a frame.
- If we have “n” connection a frame is divided in to “n” time slots and one slot is allowed for each unit. i.e. n input connections $\rightarrow n$ time slots.
- One for each input line, if the duration of input is T , the duration of each slot is T/n and the duration of each frame is T .
- Data rate of link must be n times the duration of a time slot to guarantee flow of data.
- Time slots are grouped into frames; one complete cycle of time slots; each slot dedicated to one device.
- A simple TDM process for three different data transmission is shown above.
- Here, all three data are divided into equal timeslots also called as units.
- And each data unit from all three data are combined / multiplexed together to form TDM frames comprising of small units of all three data which is further transmitted.

Q.3 Attempt any FOUR

16 marks

1) Explain basic working principle of code division multiple access technology.

Ans: **(Diagram – 2marks, Explanation-2 marks)**

Explanation:-

In CDMA more than one user is allowed to share a channel or sub channel with the help of DSSS signals. In CDMA each user is given a unique code sequence. This sequence allows the user to spread the information signal across the assigned frequency. At the receiver the signal received from various users are separated by checking the cross correlation of the received signal with each possible user sequence. In CDMA as the bandwidth as well as time of the channel is being shared by users. In CDMA the users access the channel in a random manner. Hence the signals transmitted by multiple users will overlap both in time and in frequency. CDMA does not need any synchronization.

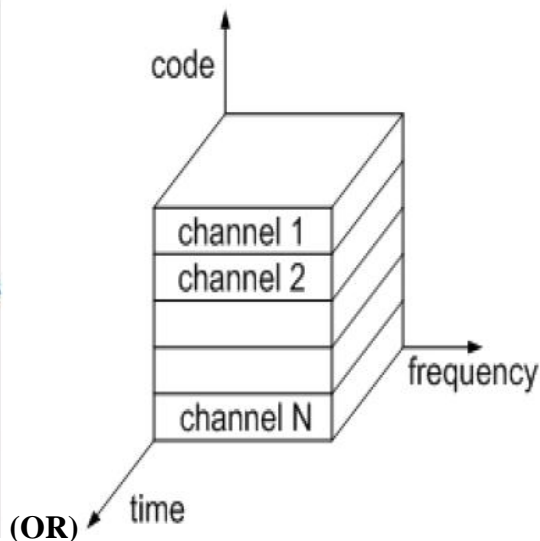
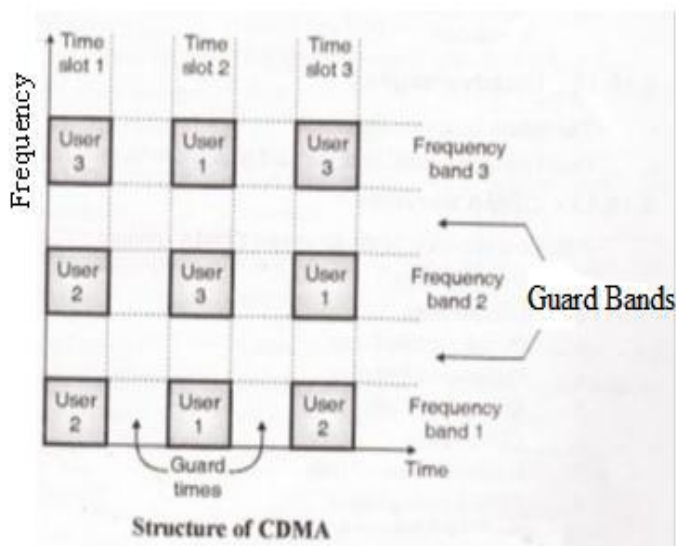

(OR)

2) Draw the block diagram of DPSK transmitter and explain.

Ans: **(Block diagram- 2 marks, explanation-2 marks)**

In BPSK receiver, the carrier recovery is done by squaring the received signal.

Hence, when the received signal is generated by negative data bit, it is squared and thus we cannot determine if the received bit is $-b(t)$ or $b(t)$. Hence DPSK is used to eliminate the ambiguity of the received bit. The DPSK transmitter is as shown -

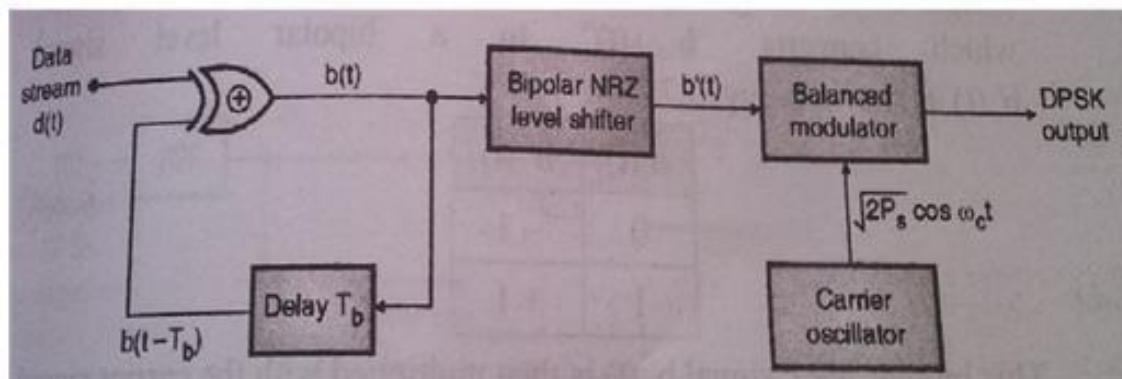

(OR)

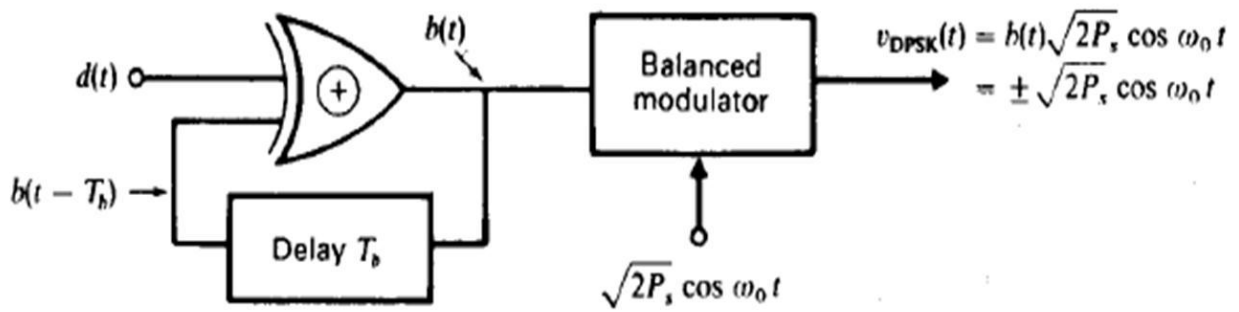

$d(t)$		$b(t - T_b)$		$b(t)$	
logic level	voltage	logic level	voltage	logic level	voltage
0	-1	0	-1	0	-1
0	-1	1	1	1	1
1	1	0	-1	1	1
1	1	1	1	0	-1

Explanation

- 1) $d(t)$ represents the data stream which is to be transmitted it is to one input of an EX-OR logic gate.
- 2) The EX-OR gate output ' $b(t)$ ' is delayed by one bit period the applied to the other input of EX-OR gate. The delayed represented by ' $b(t-T_b)$ '.
- 3) Depending on the values of ' $d(t)$ ' and ' $b(t-T_b)$ ' the EX-OR produces the output sequence ' $b(t)$ '.the waveform for the generator .the waveform drawn by arbitrarily assuming that in the first interval $b(0) = 0$.
- 4) Output of EX-OR gate is the applied to a bipolar NRZ level which converts ' $b(t)$ ' to a bipolar level " $b(t)$ " as shown

$b(t)$	$b''(t)$
0	-1
1	+1

- 5) The o/p is given as-

$$V_{Dpsk}(t) = \sqrt{2Ps} \cos \omega t$$

That Means no phase Shift has been introduced

But when $b(t) = 0$, $b''(t) = -1$ Hence

$$V_{Dpsk}(t) = \sqrt{2Ps} \cos \omega t$$

Thus 180 Phase shift is introduced to represent $b(t) = 0$.



3) State the necessity of adaptive delta modulation technique.

Ans: **(Need with proper explanation -4 marks)**

In delta modulation, the step size is constant so that its slope overload distortion and granular noise both cannot be controlled. These drawbacks can be controlled by using adaptive delta modulation wherein the step size is variable.

Thus with adaptive delta modulation the following are the advantages-

1. Slope overload distortion and granular noise problem in is reduced.
2. Improved signal to noise ratio.
3. Wide dynamic range is achieved with variable step size.
4. Better bandwidth utilization than delta modulation.

4) Compare digital pulse modulation with analog modulation.

Ans: **(Any four relevant correct points – 1 mark each)**

Sr. No	Digital Pulse modulation	Analog/Continuous wave modulation
1	The carrier is train of pulses.	The carrier is sine wave
2	The modulation can be done by varying width, position and amplitude of pulse.	The modulation can be done by varying the amplitude, phase and frequency of the sine wave.
3	More bandwidth required	Less bandwidth required.
4	Applications in Satellite communication, communication between spaceships and earth stations.	Applications in broadcasting radio and TV.
5	The noise immunity for PAM is least but rest all modulation techniques work well.	The noise immunity is low for AM. While PM and FM work well.
6	Digital modulation is possible.	Digital Modulation is not possible.
7	Simpler and less costly.	Costly and complicated

5) Explain M-ary encoding technique.

Ans: **(Proper explanation with example- 4 marks)**

In an M-ary signaling scheme, we can send one of the m possible signals such as $s_1, s_2, \dots, s_m(t)$ during each signaling interval of duration of t seconds.

The number of signals in an M is given as $M=2^n$.

The M-ary signals are obtained as follows.

Group of 'N' bits together form N bit symbols.

These signals will extend over a period of NT_b where t_b is duration of one bit.

Due to grouping of n bit per symbols, we can have $2^n=M$ possible symbols.

These M possible signals are represented by sinusoidal signals of duration $T_s = NT_b$ which differ from one another by a phase of $2\pi/m$ radians .thus M-ary signal is produced at the output.



Example: QPSK

Value of $M = 4$ also called 4aryPSK. The number of bits in one symbol are = 2.

Hence there are $2^2 = 4$ possible symbols.

Symbol1: 00

Symbol2: 01

Symbol3: 10

Symbol4: 11

Q.4 a) Attempt any THREE

12 marks

1) State historical perspective of digital communication.

Ans: **(Relevant correct explanation – 4 marks)**

Ever since human beings learnt to communicate, the goal is to send and to receive maximum information over vast distances in shortest period of time. For communication, the information signals that are mostly used are electrical in nature. The information is transmitted in the electrical form i.e., in the form of electrical current or electrical voltage and at the receiving end, the information is regenerated from its electrical outputs.

Even now, information signal can be optical in nature. Using optical mode, information can be transmitted, received and stored as well. The development of optical fibre technology is the milestone in the global telecommunications and information technology revolution. Besides voice communication, to-days' telephone companies are serving their customers' ever expanding demands like: Audio, video, fax and data transmission , Internet and multimedia services , e-mail , Video conferencing , e-business, e-education, e-banking, e-medical services.

The optical information can be transmitted through optical fiber as optical fibre can guide light. Apart from optical communication, optical fibers are being used in many different types of applications including optical inspection/surgery, non-contact sensing, traffic signs, museum illumination, etc.

History about Different Types of Communication-The basic components of a communication technology are:

- 1) Transmitter of Information signal
- 2) Carrier of signal
- 3) Receiver of signal

Considering different types of communication, the broad types can be cited, like, Radio, Television, and Satellite & optical communication.

2) List advantages and disadvantages of delta modulation techniques.

Ans: **(2 advantages-2 marks, 2 disadvantages-2 marks)**

Advantages-

- 1) Low signaling rate and low transmission channel bandwidth.
- 2) Transmitter and receiver are less costly.

Disadvantages-

- 1) Slope overload error present
- 2) Granular noise present.

3) Explain Alternate Mark inversion (AMI) coding with suitable example.

Ans: (Define- 1 mark, example with waveform—3 marks)

AMI- Alternate Mark Inversion- In this line coding a '0' is represented at zero level(0V) while alternate 1's are represented at 1V and -1V level as shown with an example-

AMI waveforms of line codes for data stream 1101001 is as shown-

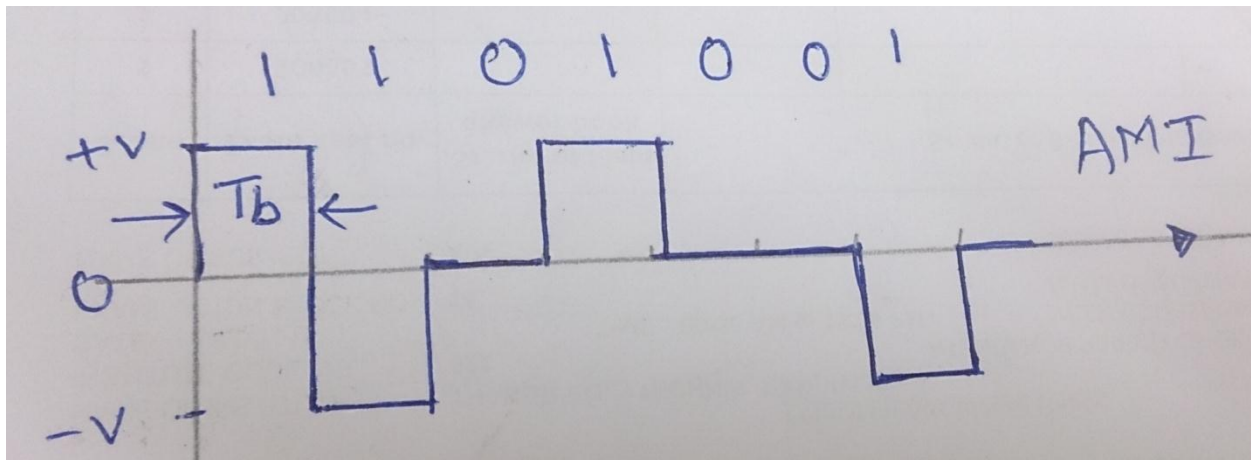

4) List and explain different types of frequency hopping.

Ans: (List-1 marks, Explanation for both 1 ½ marks each)

Types of frequency hopping-

- 1) Slow frequency hopping
- 2) Fast frequency hopping

Slow frequency hopping-In slow frequency hopping the symbol rate R_s of the MFSK signal is an integer multiple of the hop rate R_h that means several symbols are transmitted corresponding to each frequency hop.

Each frequency hop: → several symbols

Here frequency hopping takes place slowly and thus

$$\text{Hop rate } R_h > \text{Symbol rate } R_s$$

Fast frequency hopping-In fast frequency hopping, multiple frequencies or hops are used to transmit one symbol. That is each symbol-→ several hops. So several frequencies changes for one symbol such that Symbol rate $R_s > \text{Hop rate } R_h$.



Q.4 b) Attempt any ONE

6 marks

1) Generate CRC code for data word 110101011 the divisor is 01011.

Ans: (Code generation- 4 mks, generated CRC -1 mks, Final Coded data – 1 mark)

(Note - The divisor given is 01011, it should be taken as 1011 else it won't be solved)

To generate the CRC code as divisor is 4 bit, add three zeros to the data and get the remainder as shown below. The last three bit remainder is the required CRC send along with the data to be transmitted.

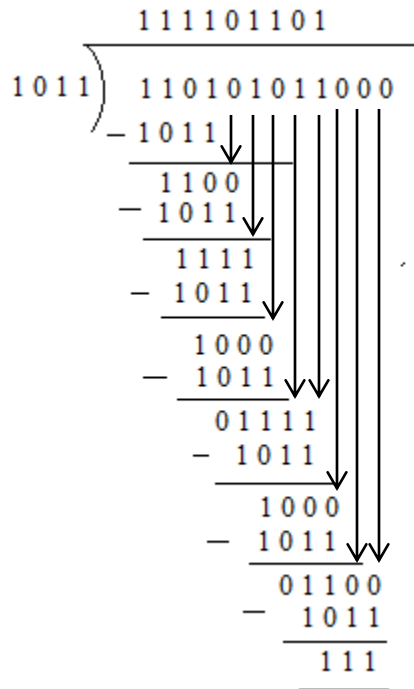

The CRC Data is 1 1 1.

The final coded data transmitted will be 1 1 0 1 0 1 0 1 1 | 1 1 1

2) Explain PN sequence generation in detail.

Ans: (Any suitable diagram - 2 marks, explanation – 2 marks, generation table - 2 marks)

Note: Diagram & generation table with four flip-flops should also be considered

A PN sequence is defined as a pseudorandom coded sequence of 1s and 0s with certain auto correlation properties.

Maximum length of PN Sequence 'L' is the no. of bits in a PN sequence and it depends upon the number of flip-flops 'n' used for the PN Sequence generator and given as

$$L=2^n - 1$$

The block diagram for 3 bit that is 7 bit length of PN sequence generator is as shown with feedback taps [3, 1]

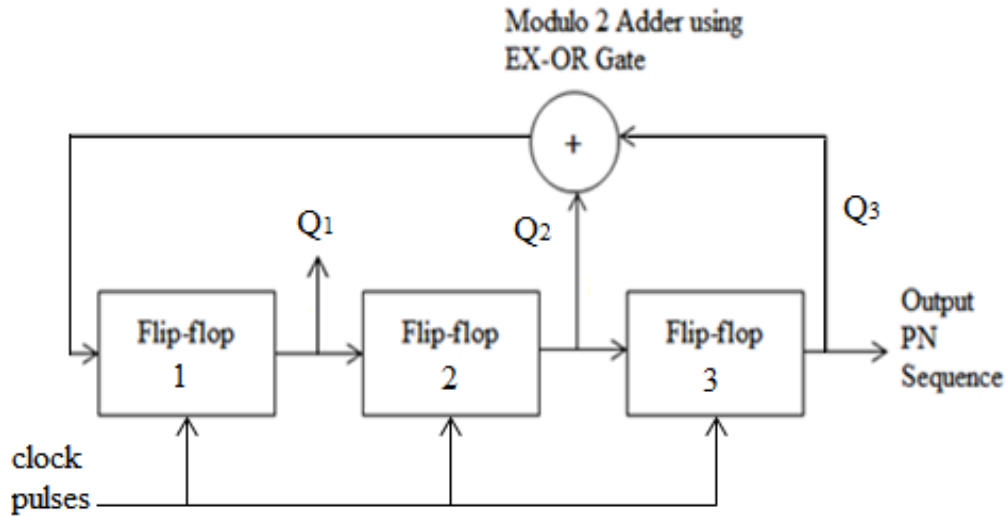

Let initial value of shift register output i.e. $Q_3 Q_2 Q_1 = 0 0 1$ (any initial value can be taken)

Table is as shown below-

Clock Pulse	Shift Register Outputs			EX-OR Gate Output	PN Sequence
	Q_3	Q_2	Q_1	$Q_3 \oplus Q_2$	Q_3
0	0	0	1	$0 \oplus 0 = 0$	0
1	0	1	0	$0 \oplus 1 = 1$	0
2	1	0	1	$1 \oplus 0 = 1$	1
3	0	1	1	$0 \oplus 1 = 1$	0
4	1	1	1	$1 \oplus 1 = 0$	1
5	1	1	0	$1 \oplus 1 = 0$	1
6	1	0	0	$1 \oplus 0 = 1$	1
7	0	0	1	$0 \oplus 0 = 0$	0
8	0	1	0	$0 \oplus 1 = 1$	0
9	1	0	1	$1 \oplus 0 = 1$	1
10	0	1	1	$0 \oplus 1 = 1$	0

The actual data repeats again and again as shown in above table with pseudorandom data bits in between to improve security of the data. Here the PN coded data will be of 7 bit.

The PN Sequence obtained at the output Q_3 of flip-flop 3 is '0 0 1 0 1 1 1 0 0 1 0'.

Q.5 Attempt any TWO

16 marks

1) Explain principle of frequency division multiplexing & compare FDM and CDM techniques.

Ans :- (Any relevant correct diagram – 2 mks, Explanation- 2 mks)

Principle of frequency division multiplexing

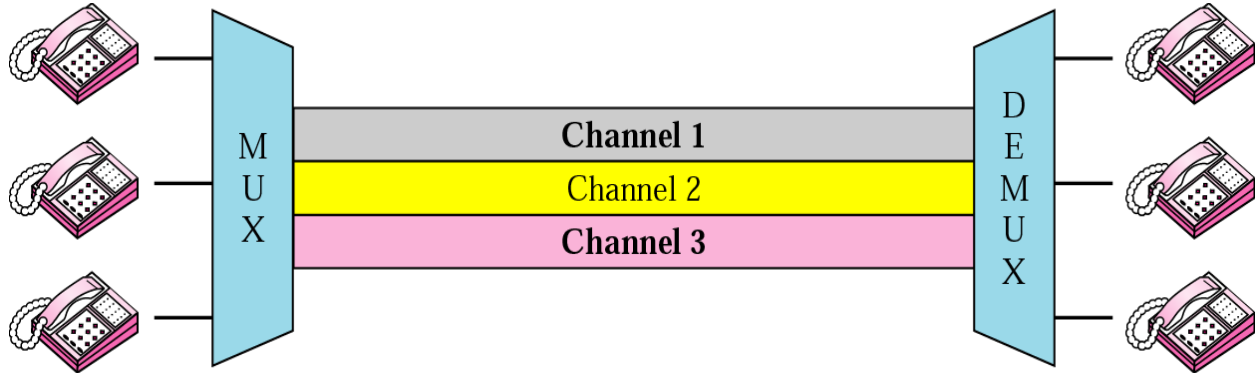

FDM means total range of frequency is divided into number of frequency slots. Each slots of frequency is allotted to each channel. Various channels of different frequencies combined, transmitted through single wire and separated at receiver with the help of De-multiplexer.

FDM can be applied when the bandwidth of the link is greater than the combined BW of the signal to be transmitted. These modulated signals are than combined into a single composite signal that can be transported by the links. Carrier frequency is separated by sufficient BW to accommodate the modulated signal .These BW range are the channel through which the various signals travels. Channels must be separated by guard bands to prevent signals from overlapping.

Comparison of FDM & CDM techniques

(Any 4 relevant points- 4 mks)

Sr.No	FDM	CDM
1	Synchronization is not required.	Synchronization is not necessary.
2	Overall bandwidth is shared among many stations.	Sharing of bandwidth and time takes place.
3	Due to non-linearity of devices inter modulation products are generated due to interference between adjacent channels.	Both type of interference will be present.
4	Code word is not required.	Code words are required.
5	Guard bands between adjacent channels are necessary.	Guard bands and guard times both are necessary.

2) Draw block diagram of QAM generation system & Explain with waveforms.

Ans: (Any Relevant correct diagram – 4 mks, explanation- 2 mks, waveforms-2 mks)

Diagram: (4 marks)

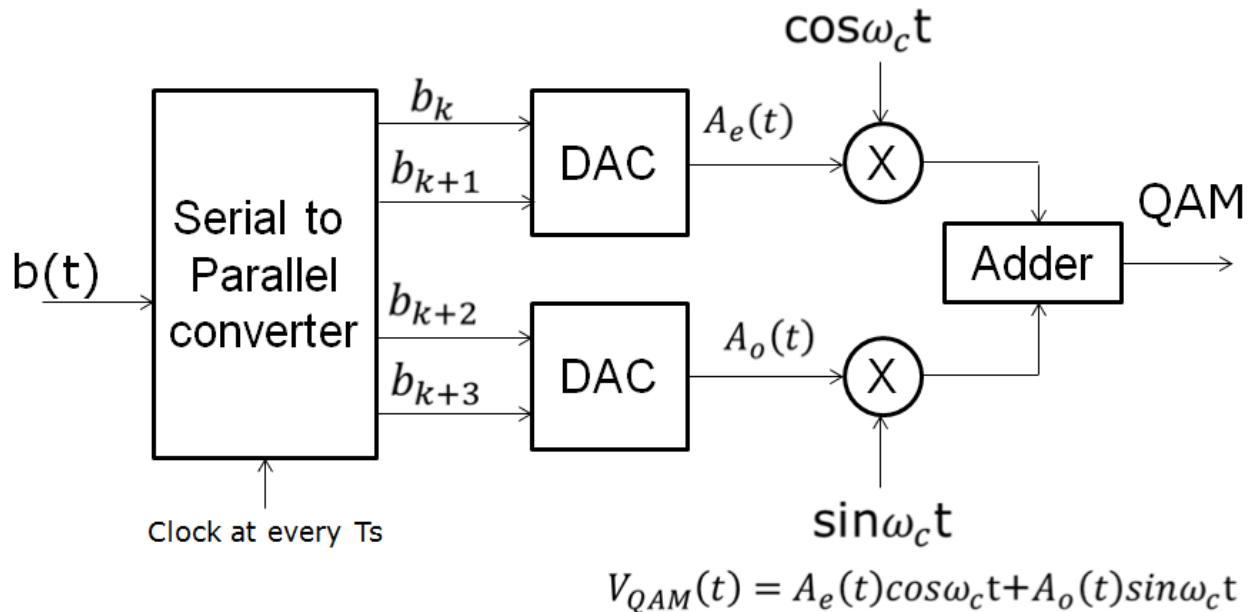

Explanation: (2 marks)

Figure shows transmitter for 4 bit QAM system. The input bit stream is applied to a serial to parallel converter. Four successive bits are applied to the digital to analog converter. These bits are applied after every T_s second. T_s is the symbol period & $T_s = 4T_b$. Bits B_k & B_{k+1} are applied to upper digital to analog converter. & B_{k+2} , B_{k+3} are applied to lower D to A converter. Depending upon the two input bits, the output of D to A converter takes four output levels. Thus $A_e(t)$ & $A_o(t)$ takes 4 levels depending upon the combination of two input bits. $A_e(t)$ modulates the carrier $\cos(2\pi f_c t)$ and $A_o(t)$ modulates $\sin(2\pi f_c t)$.

The adder combines two signals to give QAM signal. It is given as,

$$S(t) = A_e(t)\cos(2\pi f_c t) + A_o(t)\sin(2\pi f_c t).$$

(OR)

Diagram: (4 marks)

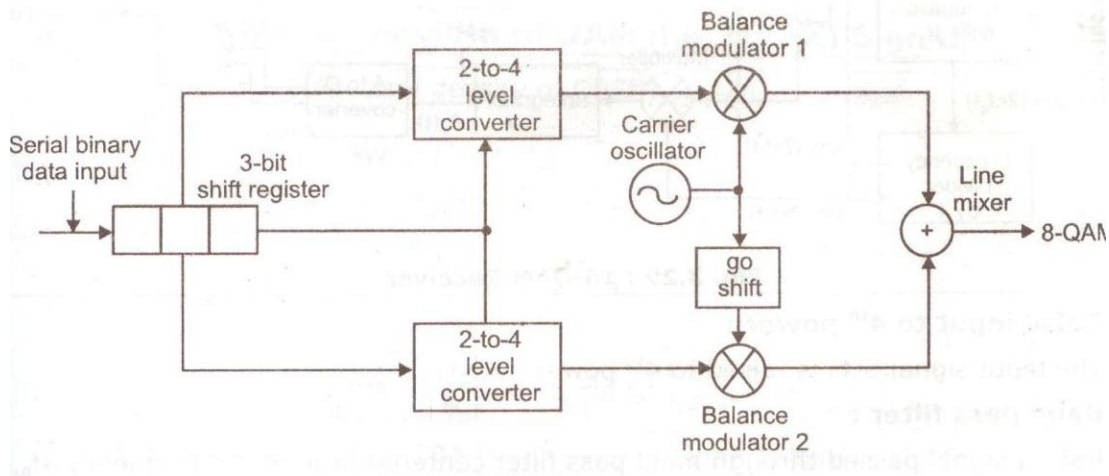

Explanation: (2 marks)

- One of the most popular modulation techniques used in modems for encoding more bits per band in QAM.
- It uses both AM and PM of a carrier.
- In addition to producing different phase shifts the amplitude of the carrier is also varied.
- A popular version of QAM is known as 8-QAM.
- This system uses four different phase shifts as in QPSK and two carrier amplitudes.
- With four possible phase shift and two different carrier amplitudes, a total of eight different states can be transmitted.
- With right states, 3 bit can be encoded for each baud or symbol transmitted.
- Each 3 bit binary word transmitted uses different PM/AM combination.
- **3-bit Shift Register:**
 - The binary data to be transmitted is shifted serially into 3-bit shift register.
- **2-to-4 level converter:**
 - 2-to-4 level converter is a circuit that translates a pair of binary inputs into one of four possible d. c. output voltage levels.
 - A 2-to-4 level converter is basically a simple D/A converter. The result is four equally spaced voltage levels.
- **Balance Modulator:**
 - The voltage levels are applied to the two balance modulators fed by the carrier and 90° phase shifter as in a QPSK modulator.
 - Each balanced modulator produces four different output PM/AM combinations.
- **Linear Mixer:**
 - When the outputs of balance modulator are combined in the linear mixer, eight different PM/AM combinations are produced.
 - This result is 8-QAM.

Waveform: (2 marks)

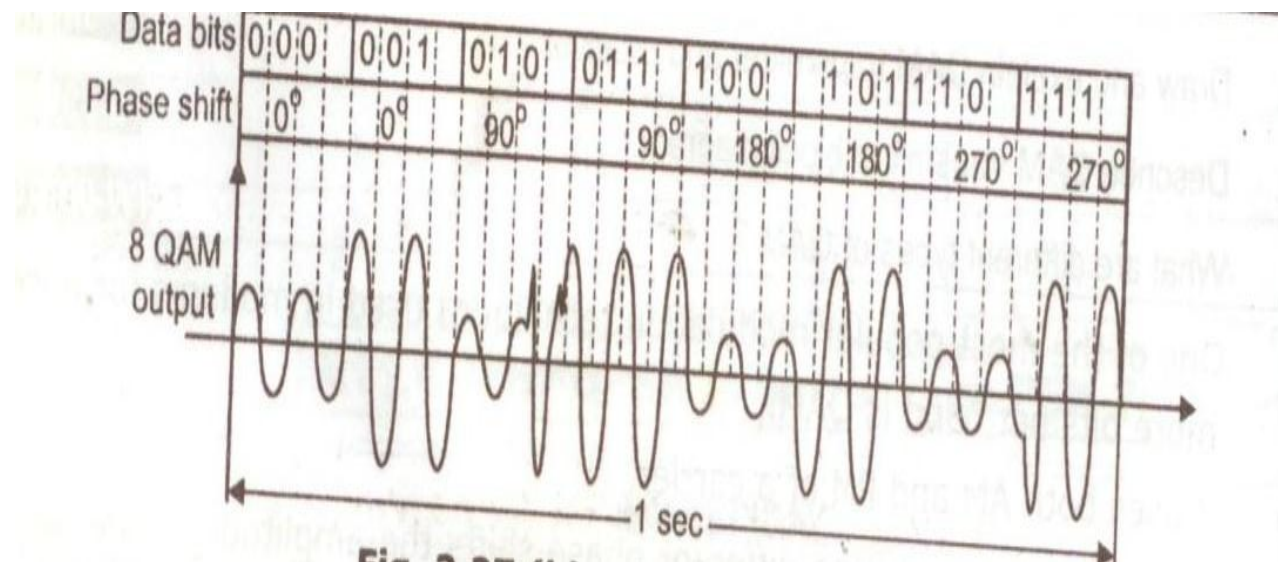

3) Describe the direct sequence spread spectrum techniques with the help of block diagram.
State advantages also.

Ans: (Diagram - 4 marks, explanation- 2 marks, advantages -2 marks (any two))

Note: DSSS receiver with explanation also should be considered and marks to be given

Direct sequence spread spectrum (DSSS):

In direct sequence, the serial binary data is mixed with a higher frequency pseudorandom binary code at a faster rate and the result is used to phase-modulate a carrier.

DSSS Transmitter:

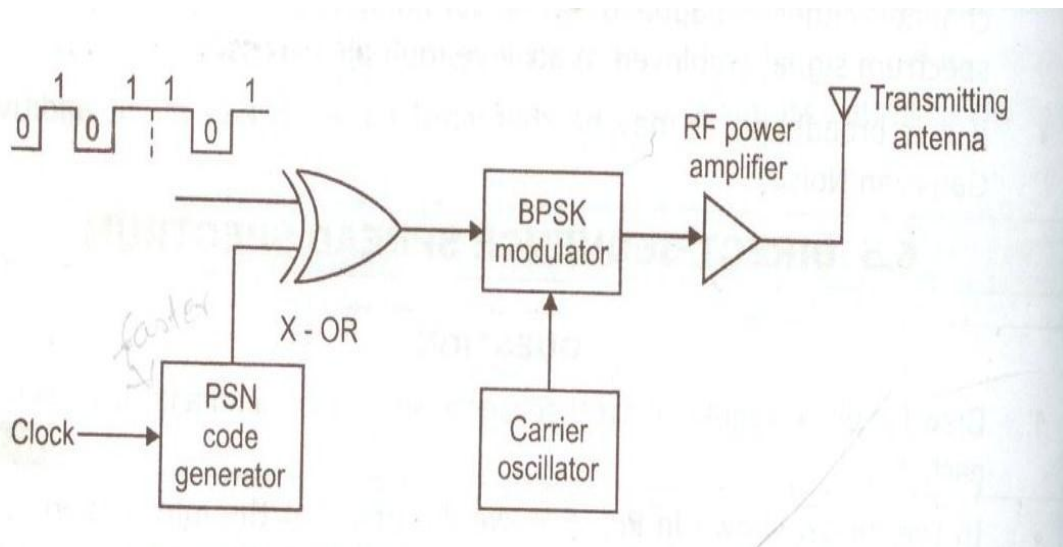

Explanation:

- A block diagram of DS transmitter is shown in figure
- The serial binary data is applied to an X- OR gate along with a serial pseudorandom code that occurs faster than binary data.
- The signal developed at the output of the X-OR gate is then applied to a BPSK modulator.
- The carrier phase is switched between 0^0 and 180^0 by the 1's and 0's of X –OR output.
- The signal phase modulating carrier, being much higher in frequency than the data signal causes the modulator to produce multiple widely spaced sidebands whose strength is such that the complete signal takes up a great deal of the spectrum. Thus the signal is spread.
- Also because of its randomness, the resulting signal is appears to be nothing more than wideband noise to a conventional narrow band receiver.
- One bit time for the pseudorandom code is called a chip and the rate of the code is called the chipping rate.
- The chipping rate is faster than the data rate.

(OR)

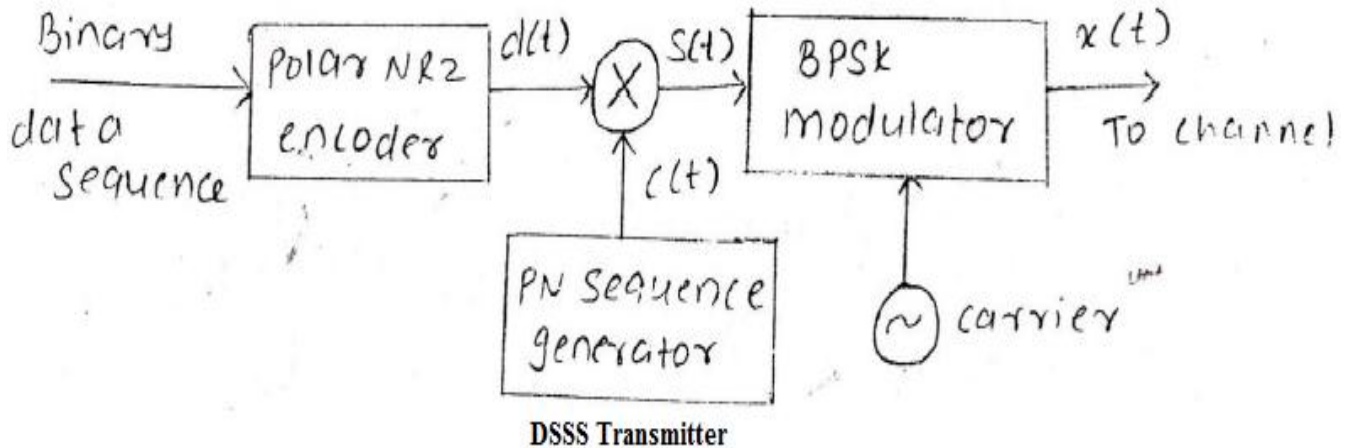

The averaging system reduces the interference by averaging at over a long period. The DSSS system is a averaging system. This technique can be used in practice for transmission of signal over a band pass channel (E.g. satellite channel). For such application the coherent binary phase shift (BPSK) is used in the transmitter and receiver.

The binary sequence $b(t)$ is given to the NRZ encoder. The $b(t)$ is converted NRZ signal $d(t)$. The NRZ signal $d(t)$ is used to modulate the PN sequence $c(t)$ generated by the PN code generator.

The multiplier multiply the signal $b(t) * c(t) = s(t)$. The $s(t)$ signal is given to binary PSK modulator.

The modulated signal at the output of product modulator or multiplier i.e. $s(t)$ is used modulate the carrier for BPSK modulation.

The transmitted signal $x(t)$ is thus DSSS signal.

Product modulator output = $s(t)$

$$s(t) = d(t) * c(t)$$

The BPSK carrier signal is given by $\sqrt{2P_s} \sin 2\pi f_c t$.

The output of BPSK modulator $x(t)$ is transmitted $x(t) = s(t) * \sqrt{2P_s} \sin 2\pi f_c t$.

But $m(t) = \pm 1$

Therefore $x(t) = \pm \sqrt{2P_s} \sin 2\pi f_c t$

The phase shift of $x(t)$ of $x(t)$ is 0° to $+m(t)$ at is 180° corresponding to a negative $m(t)$.

Advantages of Spread Spectrum (SS): (any two)

1. Unauthorized listening is prevented.
2. SS signals are highly resistant to the jamming.
3. Unintentional interference occupying the same band is greatly minimized and in most cases virtually eliminated.
4. Many users can share a signal band with no interference.
5. With SS, more signals can use a band than with any other type of modulation and multiplexing.
6. Resistant to fading.
7. The pseudorandom code makes it possible to accurately determine the start and end of a transmission.
8. Superior method for radar.

Q.6 Attempt any FOUR

16 marks

1) Explain Slope overload & Granular noise with respect to delta modulation.

Ans: (Graph – 2 marks, explanation of above two parameters – 1 mark each)

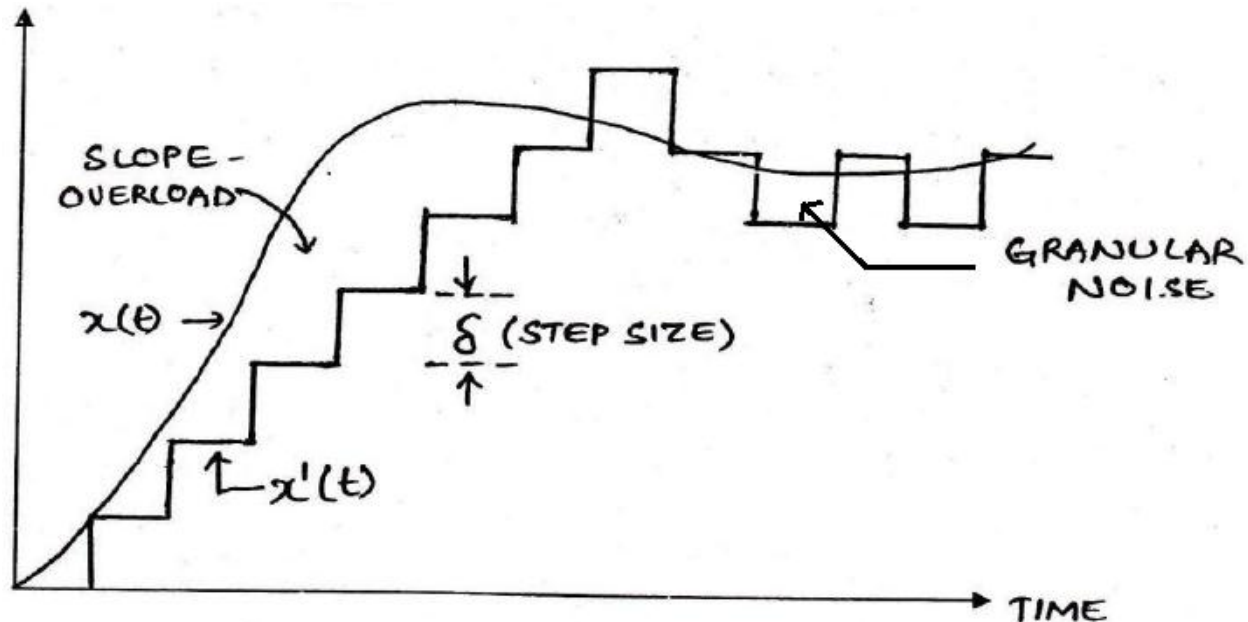

The delta modulation has two major drawbacks as under:

(i) Slope overload distortion

This distortion arises because of large dynamic range of the input signal. As can be observed from figure the rate of rise of input signal $x(t)$ is so high that the staircase signal cannot approximate it, the step size ' Δ ' becomes too small for staircase signal $x'(t)$ to follow the step segment of $x(t)$. Hence, there is a large error between the staircase approximated signal and the original input signal $x(t)$. This error or noise is known as slope overload distortion. To reduce this error, the step size must be increased when slope of signal $x(t)$ is high. Since the step size of delta modulator remains fixed, its maximum or minimum slopes occur along straight lines. Therefore, this modulator is also known as Linear Delta Modulator (LDM).

(ii) Granular or Idle Noise:

Granular or Idle noise occurs when the step size is too large compared to small variations in the input signal. This means that for very small variations in the input signal, the staircase signal is changed by large amount (Δ) because of large step size figure shows that when the input signal is almost flat, the staircase signal $x'(t)$ keeps on oscillating by $\pm\Delta$ around the signal. The error between the input and approximated signal is called granular noise. The solution to this problem is to make step size small.

Therefore, a large step size is required to accommodate wide dynamic range of the input signal (to reduce slope overload distortion) and small steps are required to reduce granular noise. In fact, Adaptive delta modulation is the modification to overcome these errors.



2) Draw RZ, NRZ Manchester & Differential Manchester line code waveform for data stream 10100110.

Ans: (Correct waveforms – 1 mark each)

Note: RZ and NRZ both Unipolar or Polar or Bipolar waveform should be considered

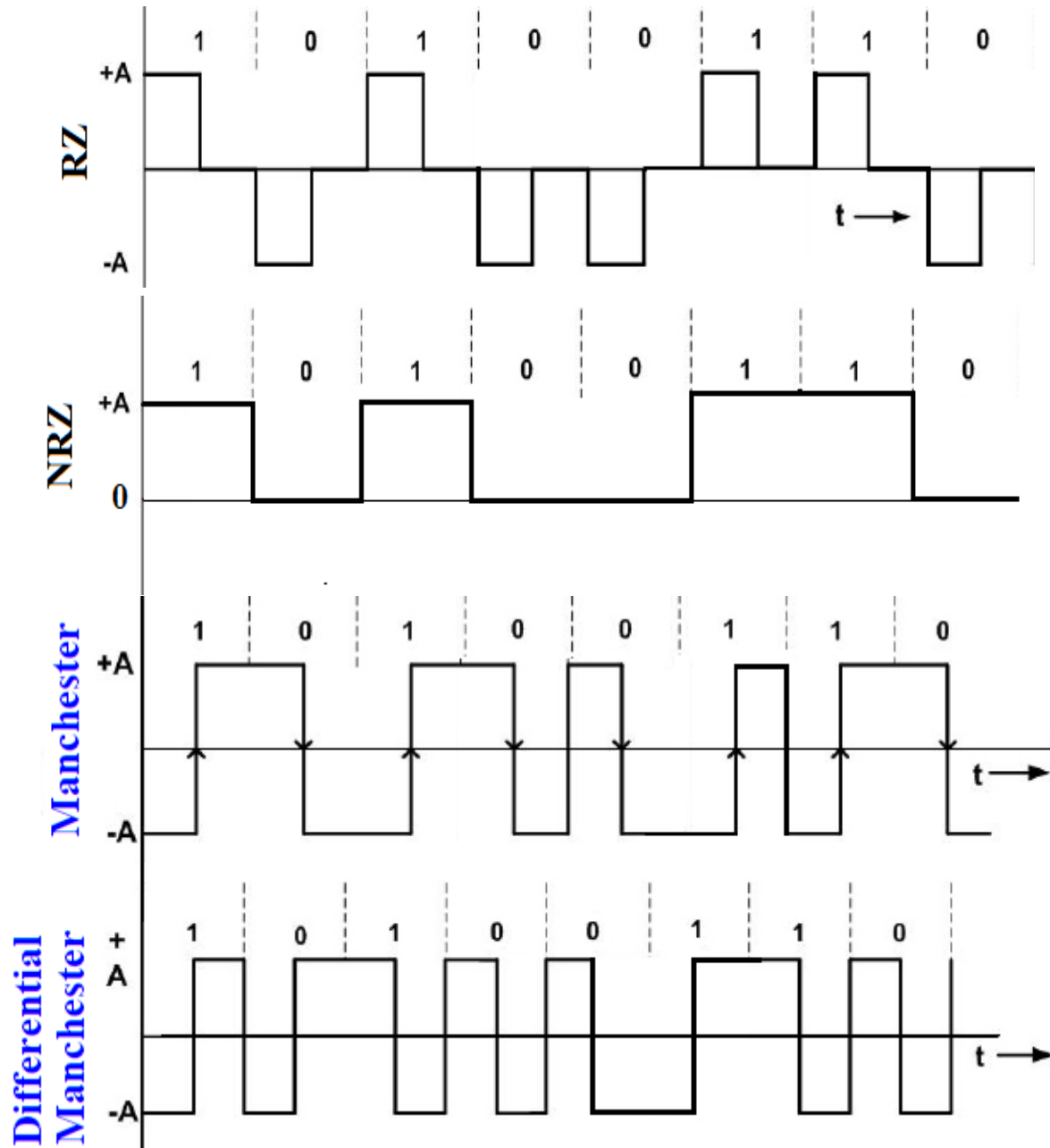



3) Compare ASK with FSK modulation.

Ans: (Any 4 relevant correct points - 4 marks)

Parameters	ASK	FSK
Variable characteristics	Amplitude	Frequency
Bandwidth (Hz)	f_b	$ f_1 - f_0 + f_b$
Noise immunity	Low	High
Error probability	High	Low
Performance in presence of noise	Poor	Better than ASK
Complexity	Simple	Moderately complex
Bit rate	Suitable up to 100bits/sec	Suitable up to about 1200 bits/sec
Detection method	Envelope	Envelope

4) List different advantages of PSK modulation.

Ans: (Any 4 advantages – 4 marks)

Advantages of PSK:

- BPSK has a bandwidth which is lower than that of a BFSK signal.
- BPSK has the best performance of all the systems in presence of noise.
- It gives the minimum possibility of error.
- BPSK has very good noise immunity.
- It gives less error of probability.
- Used for high bit rate than 1800 bits/sec.

5) Write any four specification of T carrier system.

Ans: (Any four specifications- 4 marks)

- Leased lines come in two configurations T1 and T3. A T1 line offers a data transfer rate of 1.54 million bits per second.
- A T1 line is a dedicated connection meaning that it is permanently connected to the internet.
- This is useful for web server or other computers that need to be connected to the internet all the time.
- It is possible to lease only a portion of a T1 line using one of two systems fractional T1 or Frame relay.
- You can lease them in blocks ranging from 128 kbps to 1.5 Mbps.
- The differences are not worth going into in detail but fractional T1 will be more expensive at the slower available speeds and frame relay will be slightly more expensive as you approach the full T1 speed of 1.5 Mbps.
- AT3 line is significantly faster at 45million bits per second.
- Leased lines are expensive and are generally used only by companies whose business is built around the internet or need to transfer massive amounts of data.